

REVIEW, pages 72–77

1.1

1. Use long division to divide $7x^3 + 6x^4 - 7x - 9x^2 + 8$ by $x - 1$. Write the division statement.

Write the polynomial in descending order: $6x^4 + 7x^3 - 9x^2 - 7x + 8$

$$\begin{array}{r}
 6x^3 + 13x^2 + 4x - 3 \\
 x - 1 \overline{) 6x^4 + 7x^3 - 9x^2 - 7x + 8} \\
 \underline{6x^4 - 6x^3} \\
 13x^3 - 9x^2 \\
 \underline{13x^3 - 13x^2} \\
 4x^2 - 7x \\
 \underline{4x^2 - 4x} \\
 -3x + 8 \\
 \underline{-3x + 3} \\
 5
 \end{array}$$

$$6x^4 + 7x^3 - 9x^2 - 7x + 8 = (x - 1)(6x^3 + 13x^2 + 4x - 3) + 5$$

2. Use synthetic division to divide. Write the division statement.

a) $(2x^2 - 2x + x^3 - 3x^4 + 5) \div (x - 1)$

Write the polynomial in descending order: $-3x^4 + x^3 + 2x^2 - 2x + 5$

$$\begin{array}{r|rrrrr}
 1 & -3 & 1 & 2 & -2 & 5 \\
 & & -3 & -2 & 0 & -2 \\
 \hline
 & -3 & -2 & 0 & -2 & 3
 \end{array}$$

$$-3x^4 + x^3 + 2x^2 - 2x + 5 = (x - 1)(-3x^3 - 2x^2 - 2) + 3$$

b) $(-x^4 + 4x^5 - 16 - 4x) \div (1 + x)$

Write the polynomial and binomial in descending order:

$$(4x^5 - x^4 - 4x - 16) \div (x + 1)$$

Use zeros as placeholders.

$$\begin{array}{r|rrrrrr}
 -1 & 4 & -1 & 0 & 0 & -4 & -16 \\
 & & -4 & 5 & -5 & 5 & -1 \\
 \hline
 & 4 & -5 & 5 & -5 & 1 & -17
 \end{array}$$

$$4x^5 - x^4 - 4x - 16 = (x + 1)(4x^4 - 5x^3 + 5x^2 - 5x + 1) - 17$$

1.2

3. Determine the remainder when $x^4 - x^3 - 11x^2 + 9x + 18$ is divided by each binomial. Which binomials are factors of the polynomial? How do you know?

a) $x + 2$

$$\begin{aligned}\text{Let } P(x) &= x^4 - x^3 - 11x^2 + 9x + 18 \\ P(-2) &= (-2)^4 - (-2)^3 - 11(-2)^2 + 9(-2) + 18 \\ &= 16 + 8 - 44 - 18 + 18 \\ &= -20\end{aligned}$$

The remainder is -20 .

$x + 2$ is not a factor of the polynomial because the remainder is not 0.

b) $x + 3$

$$\begin{aligned}P(-3) &= (-3)^4 - (-3)^3 - 11(-3)^2 + 9(-3) + 18 \\ &= 81 + 27 - 99 - 27 + 18 \\ &= 0\end{aligned}$$

The remainder is 0.

$x + 3$ is a factor of the polynomial because the remainder is 0.

4. For each polynomial, determine one factor of the form $x - a$, $a \in \mathbb{Z}$.

a) $4x^3 - 5x^2 - 23x + 6$

Sample response: Let $P(x) = 4x^3 - 5x^2 - 23x + 6$

The factors of 6 are: 1, -1 , 2, -2 , 3, -3 , 6, -6

Use mental math to substitute $x = 1$, then $x = -1$ to determine that neither $x - 1$ nor $x + 1$ is a factor.

$$\begin{aligned}\text{Try } x = 2: P(2) &= 4(2)^3 - 5(2)^2 - 23(2) + 6 \\ &= -28\end{aligned}$$

So, $x - 2$ is not a factor.

$$\begin{aligned}\text{Try } x = -2: P(-2) &= 4(-2)^3 - 5(-2)^2 - 23(-2) + 6 \\ &= 0\end{aligned}$$

So, $x + 2$ is a factor of $4x^3 - 5x^2 - 23x + 6$.

b) $9x^4 - 37x^2 + 4$

Sample response: Let $P(x) = 9x^4 - 37x^2 + 4$

The factors of 4 are: 1, -1 , 2, -2 , 4, -4

Use mental math to substitute $x = 1$, then $x = -1$ to determine that neither $x - 1$ nor $x + 1$ is a factor.

$$\begin{aligned}\text{Try } x = 2: P(2) &= 9(2)^4 - 37(2)^2 + 4 \\ &= 0\end{aligned}$$

So, $x - 2$ is a factor of $9x^4 - 37x^2 + 4$.

5. Factor: $x^3 - 5x^2 - 2x + 24$

Let $P(x) = x^3 - 5x^2 - 2x + 24$

The factors of 24 are: 1, -1, 2, -2, 3, -3, 4, -4, 6, -6, 8, -8, 12, -12, 24, -24

Use mental math to substitute $x = 1$, then $x = -1$ to determine that neither $x - 1$ nor $x + 1$ is a factor.

Try $x = 2$: $P(2) = (2)^3 - 5(2)^2 - 2(2) + 24$
 $= 8$

Try $x = -2$: $P(-2) = (-2)^3 - 5(-2)^2 - 2(-2) + 24$
 $= 0$

So, $x + 2$ is a factor. Divide.

$$\begin{array}{r|rrrr} -2 & 1 & -5 & -2 & 24 \\ & & -2 & 14 & -24 \\ \hline & 1 & -7 & 12 & 0 \end{array}$$

So, $x^3 - 5x^2 - 2x + 24 = (x + 2)(x^2 - 7x + 12)$

Factor the trinomial: $x^2 - 7x + 12 = (x - 3)(x - 4)$

So, $x^3 - 5x^2 - 2x + 24 = (x + 2)(x - 3)(x - 4)$

1.3

6. a) For each polynomial function below, predict the end behaviour of the graph. Justify your prediction, then use graphing technology to check.

i) $g(x) = -2x^3 + 5x^2 - 8$

The function is a cubic function with a negative x^3 -term, so I predict that as $x \rightarrow -\infty$, the graph will rise and as $x \rightarrow \infty$, the graph will fall.

ii) $h(x) = -x^4 + 2x^3 - 5x^2 + 9$

The function is a quartic function with a negative x^4 -term, so I predict that as $x \rightarrow -\infty$, the graph will fall and as $x \rightarrow \infty$, the graph will fall.

iii) $k(x) = x^4 - 2x^3 + 5x^2 - 9$

The function is a quartic function with a positive x^4 -term, so I predict that as $x \rightarrow -\infty$, the graph will rise and as $x \rightarrow \infty$, the graph will rise.

- b) What do you notice about the graphs and equations of the functions in part a, ii and iii?

The graph in part iii is the image of the graph in part ii after a reflection in the x -axis. The signs of corresponding terms in the equations are opposites.

7. Match each function to its graph. Justify your choices.

a) $y = x^4 - x^2 - 25x - 12$

b) $y = -x^4 + 8x^3 - 23x^2 + 28x - 12$

c) $y = x^5 - 3x^2 + 5$

d) $y = -x^3 + 2x + 5$

i) Graph A

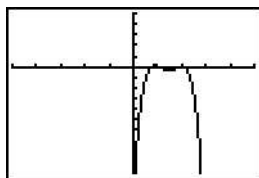

ii) Graph B

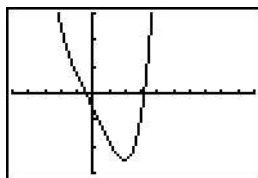

iii) Graph C

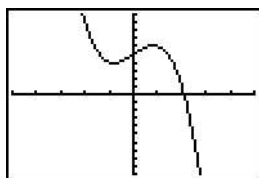

iv) Graph D

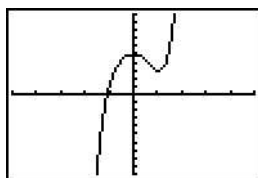

- a) Quartic function with positive x^4 -term, so graph opens up; graph B
 b) Quartic function with negative x^4 -term, so graph opens down; graph A
 c) Quintic function with positive x^5 -term, so graph falls to the left and rises to the right; graph D
 d) Cubic function with negative x^3 -term, so graph rises to the left and falls to the right; graph C

1.4

8. Sketch the graph of each polynomial function.

a) $g(x) = -x^4 - 3x^3 + 11x^2 + 3x - 10$

Factor the polynomial.

Use mental math to determine that $x - 1$ and $x + 1$ are factors.

Divide by $x - 1$.

$$\begin{array}{r|rrrrr} 1 & -1 & -3 & 11 & 3 & -10 \\ & & -1 & -4 & 7 & 10 \\ \hline & -1 & -4 & 7 & 10 & 0 \end{array}$$

So, $-x^4 - 3x^3 + 11x^2 + 3x - 10$

$= (x - 1)(-x^3 - 4x^2 + 7x + 10)$

Divide $-x^3 - 4x^2 + 7x + 10$ by $x + 1$.

$$\begin{array}{r|rrrr} -1 & -1 & -4 & 7 & 10 \\ & & 1 & 3 & -10 \\ \hline & -1 & -3 & 10 & 0 \end{array}$$

So, $-x^4 - 3x^3 + 11x^2 + 3x - 10$

$= (x - 1)(x + 1)(-x^2 - 3x + 10)$

Factor the trinomial: $-(x^2 + 3x - 10) = -(x + 5)(x - 2)$

So, $-x^4 - 3x^3 + 11x^2 + 3x - 10 = -(x - 1)(x + 1)(x + 5)(x - 2)$

The zeros of $g(x)$ are: 1, -1, -5, 2; so, the x -intercepts of the graph are: 1, -1, -5, 2

Each zero has multiplicity 1, so the graph crosses the x -axis at each x -intercept. The equation has degree 4, so it is an even-degree polynomial function. The leading coefficient is negative, so the graph opens down.

The constant term is -10 , so the y -intercept is -10 .

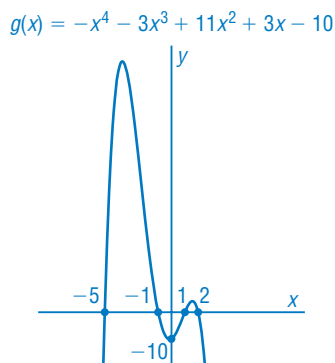

b) $f(x) = (x - 3)(x - 1)(x + 2)^2$

From the equation, the zeros of the function are: 3, 1, and -2

The zeros 3 and 1 have multiplicity 1.

The zero -2 has multiplicity 2.

So, the graph crosses the x -axis at $x = 3$ and at $x = 1$, and just touches the x -axis at $x = -2$.

The equation has degree 4, so it is an even-degree polynomial function.

The leading coefficient is positive, so the graph opens up.

The y -intercept is: $(-3)(-1)(2)^2 = 12$

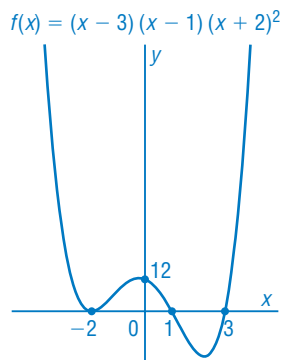

1.5

9. A piece of cardboard 26 cm long and 20 cm wide is used to make a gift box that has a top. The diagram shows the net for the box.

The shaded parts are discarded.

The squares cut from each corner have side length x centimetres. What is the maximum volume of the box? What is the side length of the square that should be cut out to create a box with this volume? Give your answers to the nearest tenth.

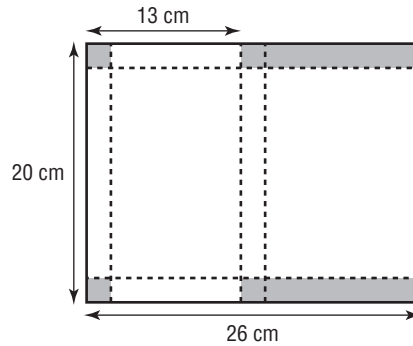

The box has height x centimetres,
width $(13 - x)$ centimetres,
and length $(20 - 2x)$ centimetres.

The formula for the volume of a box is: $V = lwh$

So, a polynomial function that represents the volume, V , of the box is:

$$V(x) = x(13 - x)(20 - 2x), \text{ or } V(x) = 2x(13 - x)(10 - x)$$

Enter the equation $y = 2x(13 - x)(10 - x)$ into a graphing calculator.

Determine the coordinates of the maximum point:

(3.7367... , 433.5979...)

The maximum volume of the box is approximately 433.6 cm^3 . This occurs when each square that is cut out has a side length of approximately 3.7 cm.